

Vibration of Main Components of Hard Disk Drive and the Vibrational Energy Transmission in Hard Disk Drive

Pinporn Tanthanasirikul* and Nopdanai Ajavakom

Department of Mechanical Engineering, Faculty of Engineering, Chulalongkorn University,
254 Phayathai Road, Pathumwan, Bangkok, 10330

Abstract

This article shows the study of the vibration of 2.5-inch hard disk drive used in a laptop by experimental method. The vibration of the hard disk drive is studied in two ways. First, the modal testing of the main components, which are a top cover, a platter, and the actuator set on the back case with the spindle motor and the vibration testing of the idling hard disk drive are done in order to identify the source of the vibration. The vibration characteristics from the vibration testing are analyzed to find the influence of each component to the occurring vibration. In addition, the relation between the frequency response functions (FRFs) and the natural frequencies of the main components from the modal testing and the vibration characteristics is studied to find the effect of the natural frequencies of each components to the overall system. The study shows that the platter is the main source of the vibration of the hard disk drive. Also, some of the natural frequency of the platter and the actuator set on the back case with the spindle motor maximizes the vibration at that natural frequency. Second, the vibrational energy transferring from the source, found from the first part of this project, modal testing and vibration testing, which is the platter, to other components is studied by using the Statistical Energy Analysis (SEA) principle. A hard disk drive system is separated into three subsystems which are the platter and rotor, the top cover, and the actuator set on the back case with the base of the spindle motor. The SEA parameters, dissipation loss factor and coupling loss factor, are found by experimental method in order to calculate the vibrational transmission energy between each subsystem.

Keywords: Vibration, Hard disk drive, Natural frequency, Statistical energy analysis

1. Introduction

A hard disk drive is necessary to the computer as the primary memory storing device of the computer. Nowadays, since computer industry is growing very fast, hard disk drives are being developed too. The goal of the development of a hard disk drive is to diminish the errors of reading and writing data as much as possible. One of the causes of the errors is the vibration of the hard disk drive. Thus, the study of vibration of the hard disk drive to identify the source and the study of the vibrational energy of the hard disk drive from the source to the others will lead to the means of reducing the vibration of the hard disk drive to get the least errors and the highest efficiency.

The vibration of the hard disk drive is studied by the experimental method, which are modal testing and vibration testing. The modal testing gives the frequency response function, which shows the specific vibration response of each component in frequency domain. The vibration testing gives the vibration characteristics of the hard disk drive which result in identifying the source of the vibration. Moreover, the vibrational energy transmission from the source of the vibration to other components is studied by applying SEA principle which appropriate to a small and complex structure like the hard disk drive. SEA is the compound of the energy knowledge and the statistics. It is very useful for complex structure because of its easiness. The SEA model is simple due to the energy dimension in spite of the fluctuation of other parameters and the spatial averaging.

2. The component of the hard disk drive

The hard disk drive is the main storage hardware of the computer devices. The hard disk drive consists of 6 main components which are a top cover, platters, a spindle motor, an actuator set, a logic board, and a back case. The top cover prevents the hard disk drive from dust and other unwanted objects. The platter is assembled to the spindle motor which rotates the platter during the working period. The platter used to store the data saved in the computer. The actuator set is the part that read and writes the data on the platter. The logic board contains the electrical control unit of the hard disk drive. The back case is where all components mounted on. The main components of hard disk drive are shown in Fig.1, 2 and 3.



Fig. 1 Top Cover



Fig. 2 Logic Board

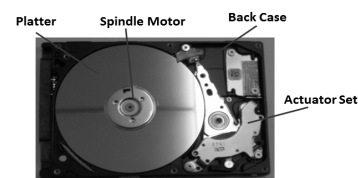

Fig. 3 The main components of hard disk drive

*Corresponding Author: E-mail: agnespin@gmail.com

3. The source of the vibration of hard disk drive

In order to identify the source of the vibration of the hard disk drive, the modal testing and the vibration testing is performed.

3.1 The modal testing

Modal testing is an experiment describing vibration characteristics of the structure. The result of the modal testing is the frequency response function (FRF) which is the ratio of the vibration response of the structure due to the applied force in frequency domain (f). The analysis of FRF contributes to the natural frequency, where the magnitude of FRF appears as a peak and the phase changes 180°. Technically, the natural frequency is the frequency that the structure still vibrates after being excited despite no external force and if the structure is applied by the external force at the same frequency as the natural frequency, the structure will excessively vibrate.

3.1.1 The experimental setup

The components of the hard disk drive are separated into 3 systems which are the top cover, the platter, and the actuator set with the spindle motor on the back case. By the reason of light weight structure, the top cover and the platter are suspended with thread to get the signal with the least noise. The heavy weight structure, the actuator set and spindle motor on the back case, is placed on the sponge. The experimental setup is shown in Fig. 4. The impact force from an impact hammer is applied to the system while the vibration response is measured in a form of acceleration by an accelerometer. The Force and acceleration signal run into the dynamic signal analyzer which cooperates with the computer in saving and analyzing the data, and displaying the results.

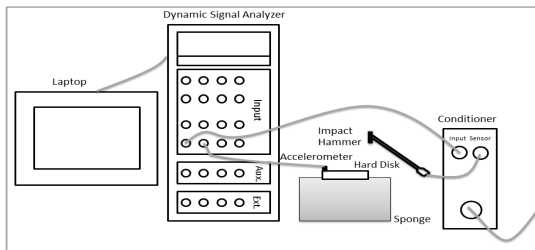

Fig. 4 The experimental setup

3.1.2 The experimental result and discussion

The frequency response function of the top cover, platter, and the actuator set with the spindle motor on the back case is shown in Fig. 5, 6, 7 respectively, while the natural frequencies analyzing from the frequency response function of each main components are shown in Table. 1.

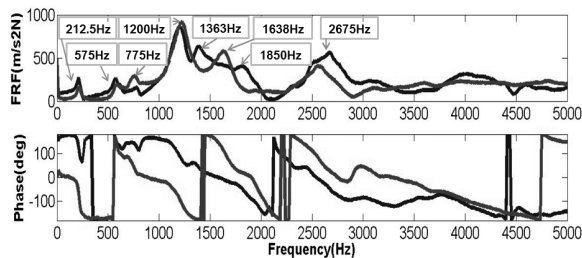

Fig. 5 The FRF of the top cover

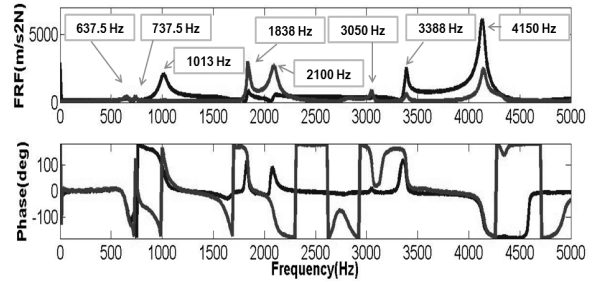

Fig. 6 The FRF of the platter

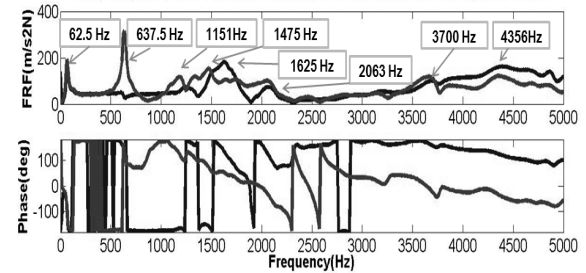

Fig. 7 The FRF of the actuator set with the spindle motor on the back case

Table. 1 Natural frequency of the main components of the hard disk drive

Natural Frequency (Hz)		
Top Cover	Platter	Actuator set on the back case with the spindle motor
212.5	637.5	62.5
575	737.5	637.5
775	1,013	1,151
1,200	1,838	1,475
1,363	2,100	1,625
1,638	3,050	2,063
1,850	3,388	3,700
2,675	4,150	4,356

3.2 The Vibration testing

The vibration testing of the idling hard disk drive, where no data is read and written, is done in order to find the vibration characteristics which lead to the finding of the source of vibration.

3.2.1 The experimental setup

The vibration testing of 8 cases of the hard disk drive are shown in Table.2. The dark shade represents the existence of the component of each case. The system is placed on the sponge to reach the free-boundary condition and is measured for the vibration characteristics with an accelerometer. Two positions as shown in Fig. 8 are measured acceleration each case. The tachometer is used to measure the rotational speed of the spindle motor. The signal from the accelerometer and the tachometer run into the dynamic signal analyzer which cooperates with the computer in saving and analyzing the data, and displaying the result. The experimental setup of the vibration testing is shown in Fig. 9.

Table. 2 The 8-cases of vibration testing

Case	Top Cover	Platter	Actuator Set	Spindle Motor	Back Case
1					
2					
3					
4					
5					
6					
7					
8					

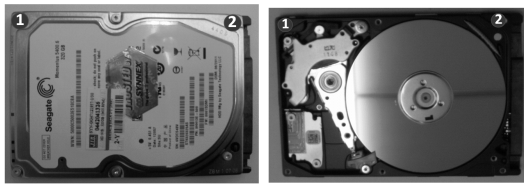

Fig. 8 the measuring position

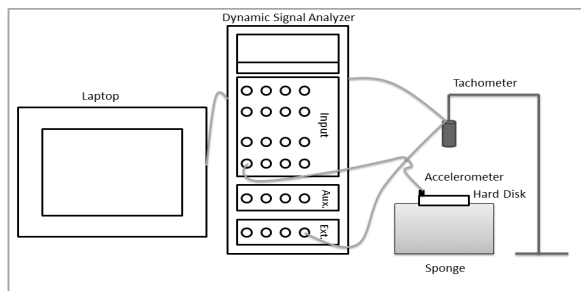

Fig. 9 The experimental setup

3.2.2 The experimental result and discussion

The vibration characteristic of the complete hard disk drive shows that the vibration occurs in the frequency range of 0-5,000 Hz including 6 peaks at 6 frequencies which are 12.5, 87.5, 1100, 1450, 1700, 1850 Hz as shown in Fig. 10. The second peak is the highest peak of all.

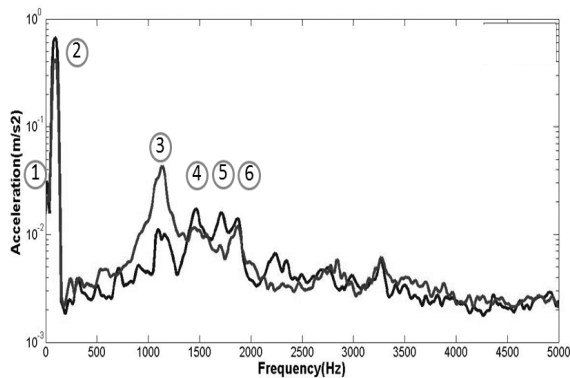

Fig. 10 The vibration characteristic of the complete hard disk drive

The vibration characteristic in a form of the acceleration magnitude of each case at the six frequencies is compared with other cases so as to find the influence of the main component to the overall hard disk drive. According to Table 3, the effect of each component, the top cover, the platter, and the actuator set, is considered from the mean value of the different of the magnitude of the vibration between the case with and without that component. The bold numbers, which are the highest values of each peak, show the component contributing the highest vibration of each peak. Since the second peak has the highest magnitude, the component that effects the vibration of this peak is important. The analysis shows that the platter is the main effect of the second-peak frequency. Considering all result, the comparison shows that having platter makes the vibration of the hard disk drive at all six peaks increased. While the vibration of the hard disk drive with the top cover is less than the vibration of the hard disk drive without the top cover. The actuator set effects the vibration of the hard disk drive at some frequency but only a little.

Table. 3 The Comparison of the vibration between each case of the hard disk drive

Case	Acceleration (m/s ²)					
	1 st Peak	2 nd Peak	3 rd Peak	4 th Peak	5 th Peak	6 th Peak
	12.5 Hz	87.5 Hz	1100 Hz	1450 Hz	1700 Hz	1875 Hz
1	0.0312	0.6650	0.0110	0.0173	0.0161	0.0139
2	0.0348	0.7310	0.0112	0.0175	0.0099	0.0139
3	0.0289	0.1710	0.0073	0.0021	0.0092	0.0028
4	0.0336	0.7480	0.0129	0.0194	0.0043	0.0032
5	0.0795	0.9730	0.0104	0.0020	0.0031	0.0022
6	0.0215	0.1120	0.0053	0.0034	0.0045	0.0028
7	0.0713	0.0910	0.0075	0.0029	0.0039	0.0022
8	0.0344	0.7310	0.0184	0.0122	0.0079	0.0070
The effect of the top cover	0.0050	0.2560	0.0027	0.0024	0.0038	0.0010
The effect of the platter	0.0246	0.4945	0.0058	0.0140	0.0044	0.0070
The effect of the actuator set	0.0262	0.2265	0.0036	0.0019	0.0051	0.0047

Furthermore, the relation between the vibration characteristic from the vibration testing and the natural characteristic from the modal testing is studied as shown in Fig.11, 12, and 13. The study shows that the natural frequencies of the top cover have no effect to the vibration of the hard disk drive, while some of the natural frequencies of the platter and the actuator set with the spindle motor on the back case have little effect as shown with the line on the following figures.

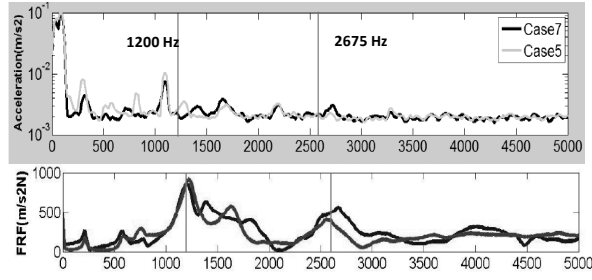

Fig. 11 The relation between the vibration characteristic of hard disk drive with (Case 7) and without top cover (Case 5) and FRF of the top cover

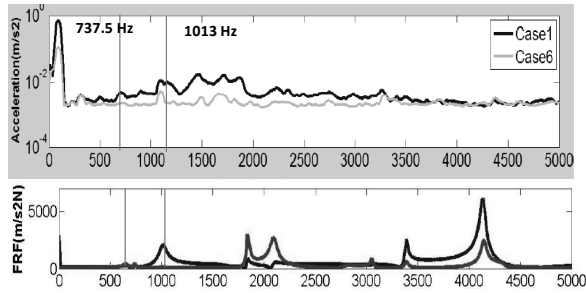

Fig. 12 The relation between the vibration characteristic of hard disk drive with (Case 1) and without platter (Case 6) and the FRF of the platter

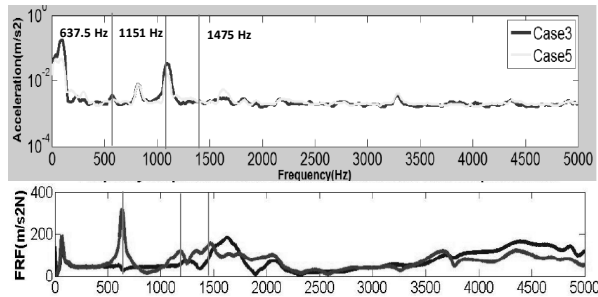

Fig. 13 The relation between the vibration characteristic of hard disk drive with (Case 3) and without actuator set (Case 5) and the FRF of the actuator set with the spindle motor on the back case

4. The vibrational transmission energy of hard disk drive

The vibrational transmission energy of the hard disk drive from platter, the source of the vibration of the overall hard disk drive to other main components is studied by using SEA experimental method. The study of the vibrational energy transmission of the hard disk drive gives an alternative of finding the means of reducing the vibration of the overall hard disk drive. Reducing the vibration of the source is not the only way of reducing the overall vibration but also reducing the transmission of the vibrational energy from the source to other components. In this study, the hard disk drive is separated into subsystems. The dissipation loss factor and coupling loss factor are determined in order to find the transmission power.

4.1 The statistical energy analysis

The statistical energy analysis (SEA) is the important tools of studying the vibration in the form of the vibrational energy. SEA is the combination of the energy principle and statistics. The main concept of SEA is that the system is separated into subsystems which are the group of components having similar energy storage modes. Each subsystem is receiving, storing and exchanging energy to one another and environment. The input power ($P_{i,in}$) is a known factor found from the input force (F) and velocity response at the input position (v_{in}). The storing energy (E_i) of each subsystem and the transfer power (P_{ij}) between each subsystem are determined by the SEA parameters which are the dissipation loss factor (η_i) and coupling loss factor (η_{ij}) relatively.

4.2 Subsystem (SS)

The hard disk drive is partitioned into three subsystems as shown in Fig. 14. The three subsystems are the platter set with the rotor, the top cover, and the actuator set on the back case with the base of spindle motor, respectively.

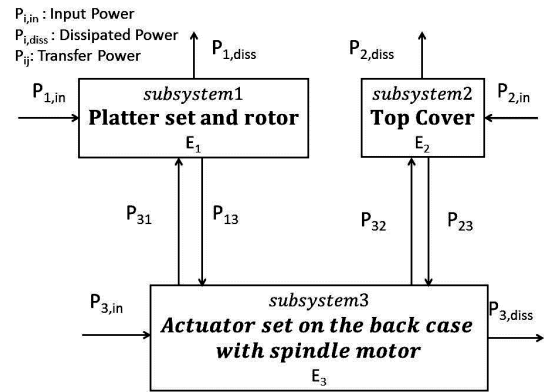

Fig. 14 Subsystem of Hard Disk Drive

The power flow of the three subsystems is also shown in Fig. 14. The input power is the power from the force excited to the system. The dissipated power ($P_{i,diss}$) is the loss power which will not return to the system, like the power radiated to the environment [5]. The transfer power is considered from the assembly of the subsystems. If the two subsystems are attached together, there is a power transfer between the subsystems. According to the assembly of the components of the hard disk drive, the first subsystem (SS1), the platter set and rotor, is only assembled to the third subsystem (SS3), the actuator set on the back case with the spindle motor, while the second subsystem, the top cover, is only mounted to the part of SS3, the back case, so in this case there are the transfer power between SS1 and SS3 and between SS2 and SS3.

4.3 Dissipation loss factor

The dissipation loss factor is the ratio of dissipated energy per unit of time and average stored energy as shown in Eq. (1) [5].

$$\eta_i = \frac{P_{i,diss}}{2\pi f E_i} \tag{1}$$

The dissipation loss factor is one of the parameter that shows the vibration characteristic of the subsystem. It brings about to the dissipation of the stored energy in each subsystem.

4.3.1 The experimental setup

The dissipation loss factor of each subsystem is determined by using the measurement of input power technique. According to this technique, the dissipation loss factor is then given as shown in Fig. 15. Force (F) and acceleration (a) at the excited position is measured in order to find the input power (P_{in}). The spatial velocity (\bar{v}), the mean velocity over the area (A) and the mass (M) of the subsystem is measured to complete the formula. The subsystem is placed on the sponge for the free-boundary condition. Force, acceleration and velocity signal measuring by force sensor, accelerometer and laser doppler vibrometer run into the dynamic signal analyzer which working with the computer in saving and analyzing the data, and displaying the results. The experimental setup is shown in Fig. 16.

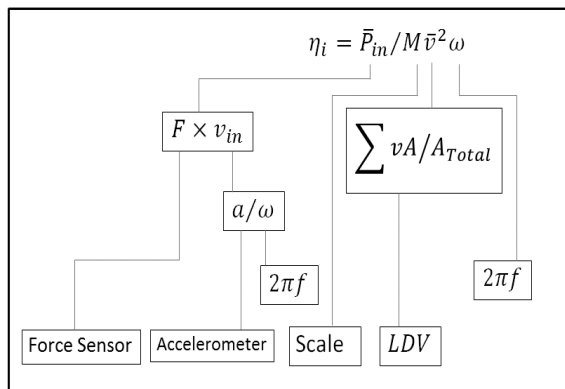

Fig. 15 The measuring input power technique

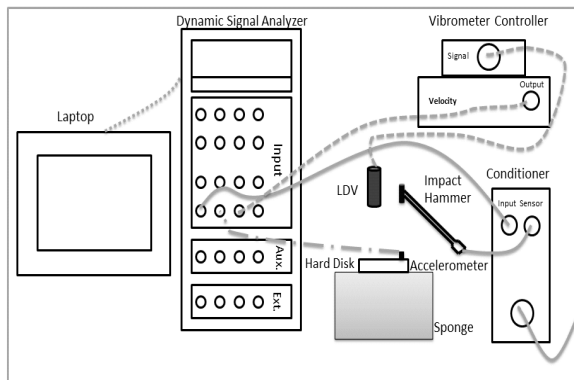

Fig. 16 The experimental setup

4.3.2 The experimental result and discussion

The dissipation loss factors are calculated from the experimental result following the input power technique. The dissipation loss factors of SS1, SS2, and SS3 are considered with the FRF of the platter, the top cover, and the actuator set on the back case with the spindle motor respectively as shown in Fig. 17.

On the ground of the formula of the input power technique, the relation between the dissipation loss factor and the FRF is that the dissipation loss factor tends to be inversely proportional to the FRF. The experimental

result that the dissipation loss factor diminishes at the natural frequency corresponds to the relation in the formula. The frequency shown in Fig. 16 is the example showing the relation between the dissipation loss factor and the natural frequency.

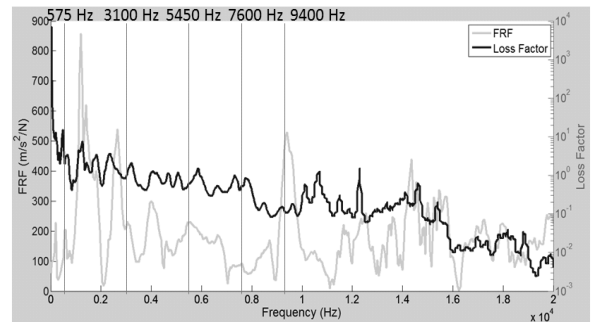

(a) SS1

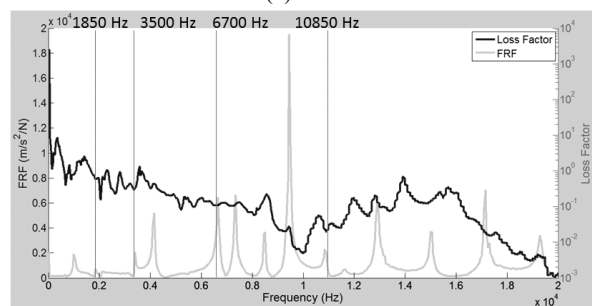

(b) SS2

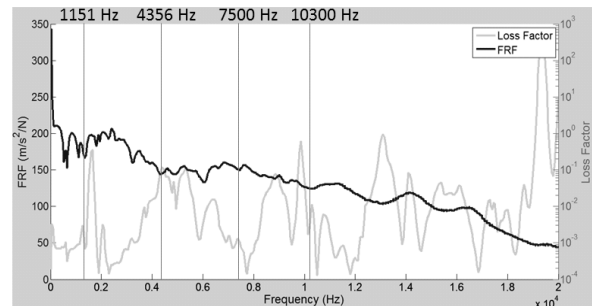

(c) SS3

Fig. 17 The relation between the loss factor and the FRF

4.4 Coupling loss factor

Coupling loss factor is the parameter that represents the characteristic of the transferring energy between the coupled subsystems. The coupling loss factor results in the transferring power between each subsystem.

4.4.1 The experimental setup

The coupling loss factors of the two couples, which are the couple of SS1 and SS2 and the couple of SS1 and SS3, are studied in this project. The technique using in this experiment is shown in Fig. 18. This formula is from Lalor's study [5]. Each coupling loss factor is determined by three sub-experiments as shown in Table. 4 to find all value which are the energies (E_{ji} , E_{ij} , and E_{jj}) and the power (P_j) in the formula. The velocity signal measuring by the laser doppler vibrometer is used to calculate the energy, while the force and acceleration signal getting from the force sensor and

accelerometer is used to find the power in this equation. The experimental setup is shown in Fig. 19.

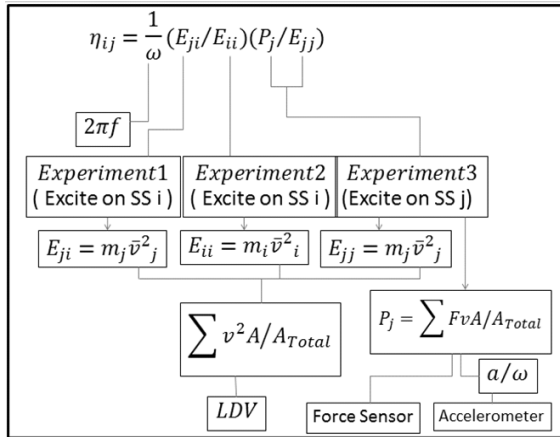

Fig. 18 The coupling loss factor

Table. 4 The Sub-experiment of finding coupling loss factor

Sub-Experiment	Objective	Excited Subsystem	Response-Measuring Subsystem
1	Find E(jj)	i	j
2	Find E(ii)	i	i
3	Find E(ij) and P(j)	j	j

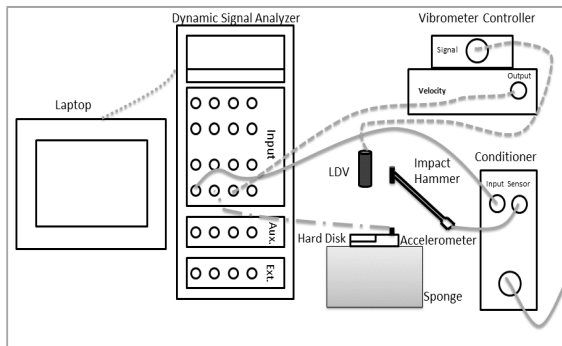

Fig. 19 The experimental setup

4.4.2 The experimental result and discussion

The coupling loss factors between each coupled subsystem, η_{13} , η_{31} , η_{23} , and η_{32} , are shown in Fig. 20. Since the coupling loss factor represent the characteristic of the energy transfer, the relation between the coupling loss factor and the vibration characteristic of the complete hard disk drive (Case 1) is studied in order to find the relation between the characteristic of the vibrational energy transfer and the occurring vibration. The relation between the coupling loss factor and the vibration characteristic shows that where the coupling loss factor is high, the magnitude of the vibration is high as well, like at 625, 1100, 1700, 2500 Hz as shown in Fig. 21. This means that the more the vibrational energy transfer, the more the vibration occurs.

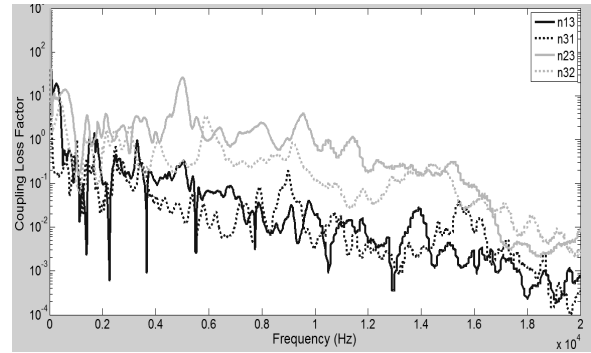

Fig. 20 The coupling loss factor

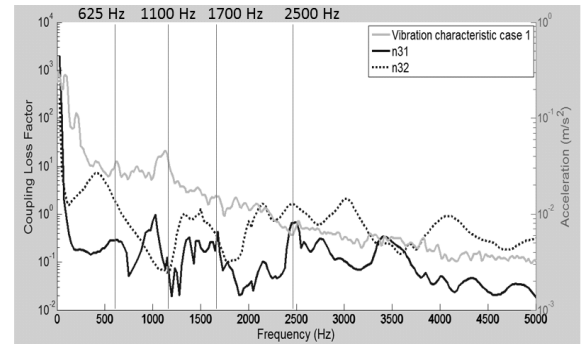

Fig. 21 The relation between the coupling loss factor and the vibration characteristic of the complete hard disk drive

4.5 Transmission power

Transmission power between subsystems is the different between the transfer powers between each subsystem. The transfer power can be calculated from Eq. (2), whereas the transmission power can be determined from Eq. (3).

$$P_{ij} = \omega \eta_{ij} E_i \quad (2)$$

$$P_{transmission} = P_{ij} - P_{ji} \quad (3)$$

Transfer powers and Transmission powers between subsystems are shown in Fig. 22 and 23 respectively.

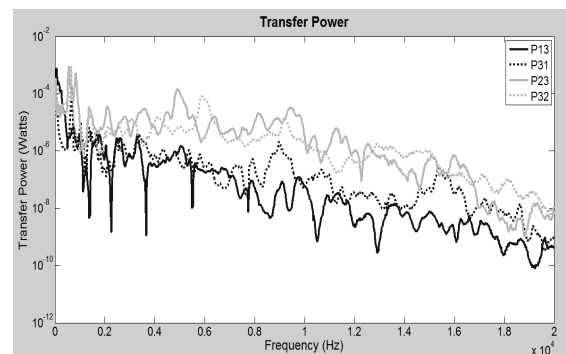

Fig. 22 Transfer power

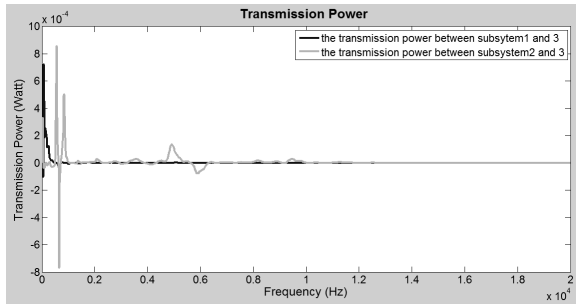

Fig. 23 The transmission power (0-20kHz)

The transmission powers between SS1 and SS3 and between SS2 and SS3 at the high range frequencies, 10-20 kHz, are virtually zero, while at low range frequencies, the transmission power at some frequencies shows as a peak. The vibration power transmitted between SS1 and SS3 is less than between SS2 and SS3. The peak of the transmission power between SS1 and SS3 occurs at 80, 125, 225 and 650 Hz, whereas the peak of the transmission power between SS2 and SS3 occurs at 550, 650, 800, 1450, 2100, 3400, 4900, 5850, 9450 Hz. All these frequency is very near some of the natural frequency of some main components. Fig.24 is the example of the relation between the transmission power and the FRF of the platter. Also, some frequencies are close to the frequencies that have high vibration magnitude as shown in Fig.25.

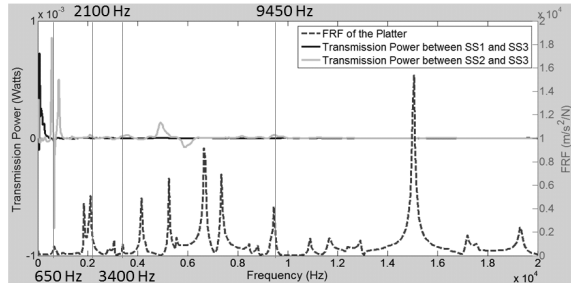

Fig. 24 The relation between the transmission power and the FRF of the Platter

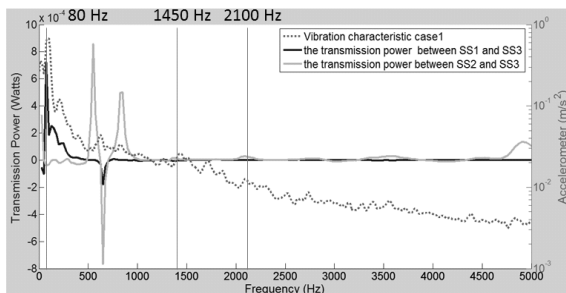

Fig. 25 The relation between the transmission power and the vibration characteristic (0-5kHz)

5. Conclusions

The vibration of the hard disk drive studying in this project consists of two parts which is to identify the source of the vibration and to study the transmission of the vibrational energy from the source to other components. In order to identify the source of the vibration, the modal testing is performed to the main components of the hard disk drive, and the vibration testing of the idling hard disk drive is done as well. The modal testing experimental results, FRFs, are analyzed with the vibration testing experimental results, the vibration characteristics of the hard disk drive, in order to find the impact of the natural frequencies of the main components of the hard disk drive to the overall vibration. The analysis shows that some modes of the natural frequencies of the platter and the actuator set on the back case with the spindle motor effect the overall vibration and from the comparison of the vibration characteristics shows that the platter is the main source of the vibration of the hard disk drive. For the purpose of studying the vibrational energy transmission from the platter to other components, SEA was used as a tool in this study. SEA parameters, which are dissipation loss factor and coupling loss factor, of the three subsystems, two platters with a rotor, top cover, and actuator set on the back case with the spindle motor, are first identified by the calculation of the data given from the experiments. Then, the transmission energies between SS1 and SS3 and between SS2 and SS3 are calculated. The results show that the vibrational energy transmission between the top cover (SS2) and the actuator set on the back case with the spindle motor (SS3) is higher than the transmission between the platter set (SS1) and the actuator set on the back case with the spindle motor (SS3), and also the vibrational energy is transfer much at some of the natural frequencies and the frequencies with high vibration magnitude.

6. References

- [1] Dr. Peter Avitabile. Modal Space in Our Own Little World. Sound & Vibration Magazine (Jan 2001), SEM & Blackwell Publishing (Feb1998-June2007).
- [2] I.Y. Shen. Recent Vibration Issues in Computer Hard Disk Drives. Journal of Magnetism and Magnetic Materials 209 (2000): 6-9.
- [3] E. Sarradj. Energy-Based Vibroacoustics: SEA and Beyond. Journal of Sound and Vibration, 2003.
- [4] K. Delaere, Statistical Energy Analysis of Acoustic Noise and Vibration for electric motors: transmission from air gap field to motor frame. Industry Application Conference, 1999. Thirty-Fourth IAS Annual Meeting. Conference Record of the 1999 IEEE, Vol. 3. pp. 1897-1902.
- [5] Cimerman, B., Bharj, T., and Borello, G., Overview of the Experimental Approach to Statistical Energy Analysis, SAE Technical Paper 971968, 1997.
- [6] S.S.Rao. Mechanical Vibrations. SI Concersion by Yap Fook Fah. 4th Edition. Singapore: Prentice Hall, 2005.
- [7] D.J. Inman. Engineering Vibration. 3rd Edition. United States of America: Pearson Education, Inc, 2008.
- [8] R.H. Lyon. Statistical energy analysis of dynamical systems: theory and applications. United States of America: the Massachusetts Institute of Technology, 1975.
- [9] C.W. de Silva. Vibration and Shock Handbook. Taylor and Francis Group, LLC, 2005.

- [10] J.F. Fieras, J. C. Lai, C. Wang. Noise of Polyphase Electric Motor. Taylor and Francis Group,2006.
- [11] The Fundamentals of Signal Analysis. Application Note243. U.S.A.: Hewlett Packard, 1994.
- [12] The Fundamentals of Modal testing. Application Note243-3. U.S.A.: Hewlett Packard, 1997.
- [13] Bearing Runout Measurements. Application Note 243-7. U.S.A.: Hewlett Packard, 1996.