

## Effect of velocity stack geometry on the performance of 150 cc-four stroke motorcycles

I Gusti Gde Badrawada, Anak Agung Putu Susastriawan\* and Yoga Pradipta

Department of Mechanical Engineering, Faculty of Industrial Technology, Institut Sains dan Teknologi AKPRIND, Indonesia

Received 27 January 2022

Revised 4 April 2022

Accepted 26 April 2022

### Abstract

This research aims to determine the effect of velocity stack geometry on the performance of 150 cc-four stroke motorcycles. Three different velocity stacks, namely VS5, VS15, and VS25 were made from Polyethylene using the 3D printing technique, with significant differences in their fillet radius and diameter inlet. A flow bench test was conducted to ascertain the internal aerodynamic qualities of the engine. The dynamometer assessment was carried out to determine its effect on the output power, torque, and specific fuel consumption of the motorcycle. The results showed that the engine expressed better performance when VS5, VS15, and VS25 were used compared to when they were not utilized. The torque and power rose slightly while specific fuel consumption reduced, when the fillet radius of the velocity stack inlet increased.

**Keywords:** Four-stroke, Geometry, Motorcycle, Performance, Velocity stack

### 1. Introduction

The performance of a motorcycle is an important criterion in obtaining satisfaction while riding on the road. Power, torque, fuel consumption, and emission are generally used to define the performance of internal combustion engines of automobiles [1, 2], including motorcycles [3, 4]. Riders need engines with high power and torque having a wide range of speeds, however, low fuel consumption and exhaust gas emission. These features are affected by certain factors, such as the intake system.

The intake system plays an important role in the aerodynamic process necessary for better engine performance, affects combustion, and engine performance. Maintenance of airflow rate is essential in obtaining a good air-fuel ratio, as complete combustion of fuel requires enough amount of air. Various works on enhancing the engine's performance by modifying the intake system have been reported in previous research. Cheviz and Akin [5] designed and tested the intake manifold with variable length plenum on spark-ignition engine performance. The assay showed that a shorter plenum intake manifold should be used for high-speed engines and vice-versa.

Silva et al. [6] worked on "Optimization of Runner Length of Intake Manifold of Four Stroke Spark Ignition Engine using 1D GT-POWER Simulation Platform." It was observed that the shorter the runner length, the greater the volumetric efficiency of the engine under high speeds condition. Reddy et al. [7] analyzed "The Effect of Convergent Inlet Manifold on the Performance of Internal Combustion Engine." It was found that the convergent inlet manifold has a higher mechanical efficiency of about 3.15% than normal. Sharma et al. [8] designed and manufactured air flow assemble for formula SAE vehicle. To reduce intake, lightweight ABS (Acrylonitrile butadiene styrene) material was used and this increased torque across the wheels through a wide range of engine RPM (revolution per minute). Therefore, the geometry of the intake manifold certainly affects the performance of the engine [9, 10].

Other strategies adopted to boost engine performance were also reported in previous research. The use of variable valve timing, impacts the torque output and air-fuel ratio [11]. Inlet valve strategies for fuel efficiency of spark ignition engine has been investigated by Teodosio et al. [12]. Both early inlet valve closure (EIVC) and late inlet valve closure (LIVC) generated an improved fuel consumption with the conventional Full Lift valve strategy. EIVC is more effective than LIVC, while similar brake specific fuel consumption (BSFC) is beneficial at high load. To obtain proper valve timing and engine breathability, the control-oriented lumped model is utilized as a useful and simple tool. This model was proposed by Morrone et al. [13], and was able to predict airflow elements during the intake process. Other research reported the use of supercharging [14] as well as turbocharge [15] to increase air mass flow rate during the intake process. Although various research on the intake system of internal combustion engines and the performance have been reported, none of them include velocity stack.

The velocity stack is mounted at the main throttle body of the carburetor as shown in Figure 1. It is used to boost the air-flow rate and attached to the air intake system of a motorcycle, as it is expected to increase the engine performance. The comprehensive report of the velocity stack geometry effect has been unavailable. Therefore, this research aims to determine the effect of velocity stack geometry on the performance of a 150 cc-four stroke motorcycle, in terms of torque, power, and specific fuel consumption.

\*Corresponding author.

Email address: [agung589E@akprind.ac.id](mailto:agung589E@akprind.ac.id)

doi: 10.14456/easr.2022.57

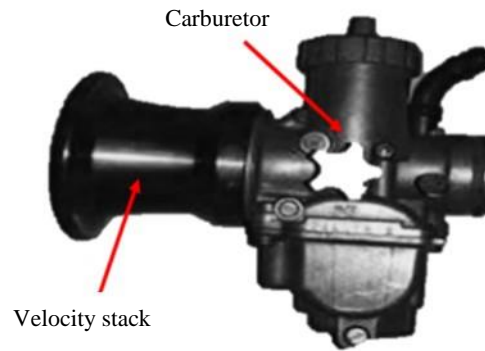

**Figure 1** Carburetor with a velocity stack

## 2. Methodology

This research is divided into three aspects, namely 1) Designing and fabricating a velocity stack, 2) Investigating flow characteristics of the stack using a flow bench testbed, and 3) Conducting a dynamometer test to determine the effect of velocity stack geometry on the performance of a 150 cc four-stroke motorcycle.

### 2.1 Design and fabrication of velocity stack

At the initial stage, three different velocity stacks were produced from Polyethylene using a 3D printing machine. Figure 2 shows an isometric and orthogonal view of the stacks labeled VS5, VS15, and VS25, having a similar length and outlet diameter of 65 mm and 30 mm, respectively. The main differences were found in the fillet radius of 5, 15, and 25 mm as well as diameter of the inlet of 68, 84, and 81 mm for VS5, VS15, and VS25, respectively.

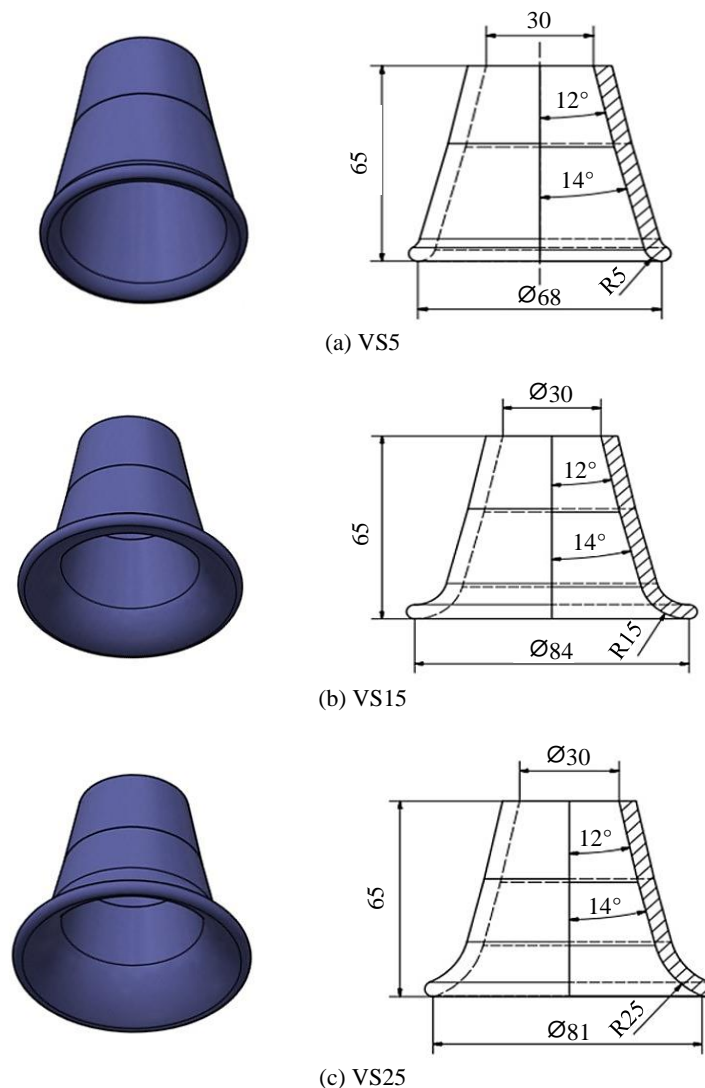

**Figure 2** Isometric and orthogonal view of the velocity stack

2.2 Flow bench test

In the second stage, the stack was tested on a flow bench to determine the airflow rate passing through them. It was placed in the test piece as indicated in a schematic diagram of the flow bench experimental setup in Figure 3. The bench used was the SF-110 series from Superflow Technologies Group, consisting of an air pump, a u-tube, and inclined manometers, as well as a thermometer. The test procedure was as follows: 1) The velocity stack was inserted in the required position; 2) The air pump was switched ON to create a vacuum in the plenum, thus ambient air enters the velocity stack; 3) Data of air pressure was collected from a u-tube and inclined manometer. The uncertainty reading of the manometer is  $\pm 1\%$  full-scale repeatability  $\pm 0.5\%$ . For each sample, the test was performed 5 times and the result was presented and analyzed in average value.

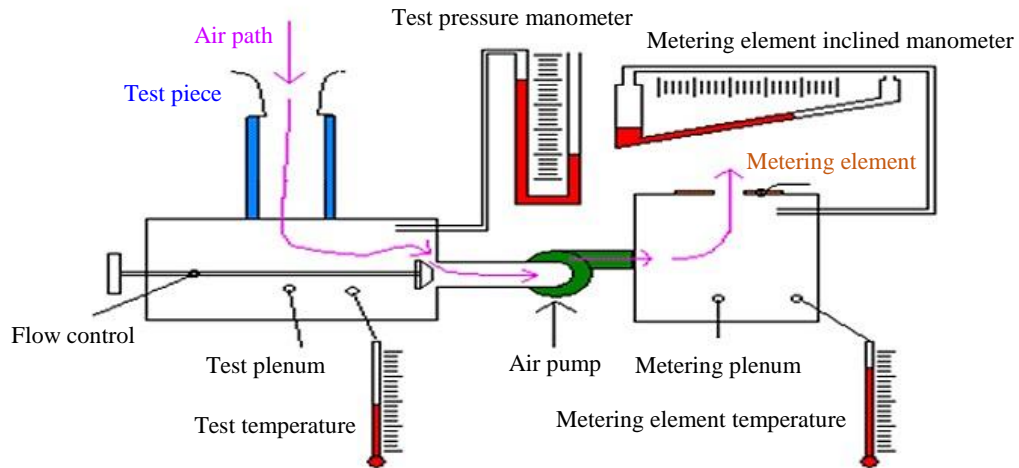

Figure 3 Schematic diagram of flow bench test setup

2.3 Dynamometer test

The stack was attached to the intake manifold of the 150 cc-four stroke motorcycle and the effect on the engine performance was determined using a dynamometer in the third stage. Figure 4 presents the schematic diagram of the dynamometer set up in the third stage. The engine performance was evaluated using the rotational speed of 6750 to 11750 rpm. The performance in terms of output power and torque were calculated by the dynamometer software and displayed on the monitor. The output torque and power generated by the engine were computed using Eqs. (1) and (2). The engine performance in terms of specific fuel consumption rate was calculated using Eq. (3).

$$T = F \times l \tag{1}$$

$$P = 2 \times \pi \times N \times T \tag{2}$$

$$SFC = \frac{P}{\rho_f \times \dot{V}_f} \tag{3}$$

Where F is the force acting on the roller, l is the radius of the roller, N is the rotational speed of the engine,  $\rho_f$  is the density of the fuel, and  $\dot{V}_f$  is the volumetric fuel consumption.

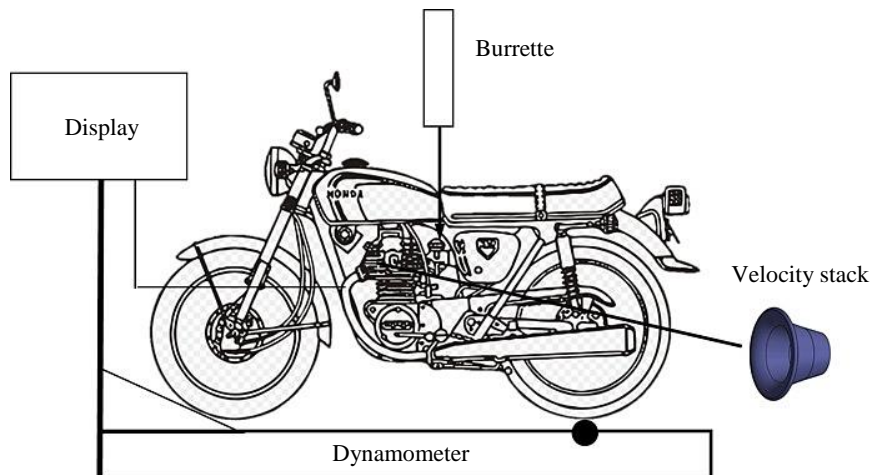
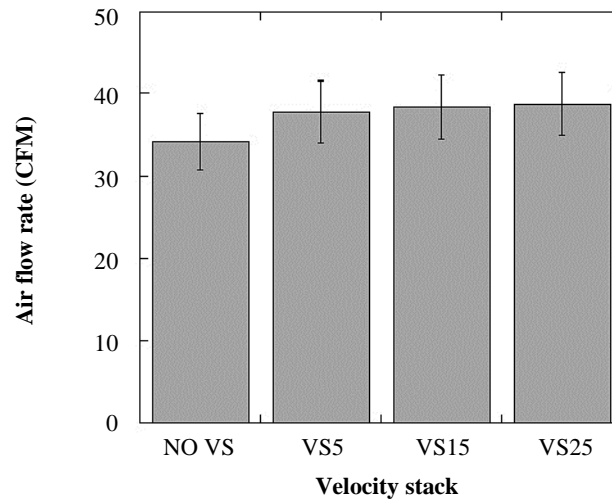

Figure 4 Dynamometer test setup

### 3. Results and discussion

#### 3.1 Airflow rate

Figure 5 shows the effect of velocity stack geometry on airflow rate during the bench test. The rate increases slightly with the rising fillet radius of the inlet section of the stack. A high amount of air enters the stack of a larger fillet radius, since flow experiences less turbulence compared with a smaller radius. Airflow rates for fillet radii of 5 mm (VS5), 15 mm (VS15), and 25 mm (VS25) are 37.76, 38.35, and 38.76 cm, respectively. These flow rates are slightly higher without velocity stack (No VS). Therefore, the airflow rate entering the chamber without VS is just 34.22 cfm. It is observed that the use of a velocity stack is able to increase the airflow rate by 13.3%. However, it changes insignificantly when the radius of the stack alters.

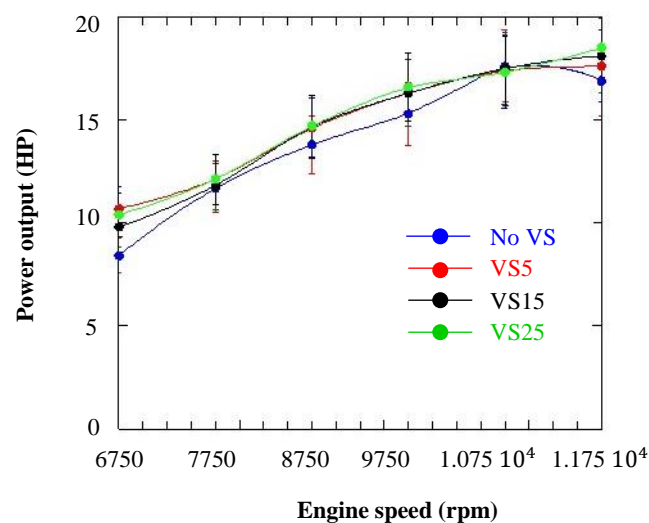

**Figure 5** Airflow rate

#### 3.2 Output power

The output power of the engine at different stack geometries and the parts without VS is shown in Figure 6. In general, the power output of the engine improves while using a velocity stack. The graph indicates that the output power of the engine is higher at VS5, VS15, and VS25 than without VS. The use of a velocity stack invariably augments the output power of the 150 cc-four stroke motorcycle. It significantly boosts output power by being attached and enabling a higher amount of air to enter the carburetor and leaner mixture. Therefore, VS enhanced the discharge of the air-fuel mixture during the combustion stage and generate more power.

In this research, the air-fuel equivalence ratio ( $\lambda$ ) are 0.68, 0.76, 0.79, and 0.88 for No VS, VS5, VS15, and VS25, respectively. Those  $\lambda$  values indicate that the use of VS15 produces the leaner air-fuel mixture entering the combustion chamber. According to Thomas [16], higher efficiency and higher power output are obtainable with leaner mixtures. Besides, improved combustion and operation with thinner combinations also reduce hydrocarbon emissions from the engine [17]. The output power is slightly higher when the fillet radius of the stack is 25 mm. The power generated by the use of VS25 is the highest, typically at an engine speed higher than 7750 rpm. However, the output power for all the four conditions of the engine is very close to each other at the speed of 7750 rpm and 10750 rpm. This is due to unstable combustion which occurs at various engine speed conditions. A similar result was also obtained by Reddy et al. [7] stating that a convergent inlet manifold has a higher mechanical efficiency of about 3.15% than the normal.



**Figure 6** Power output

### 3.3 Output torque

Figure 7 presents an effect of velocity geometry on the output torque of the engine. It was observed that the use of a velocity stack is able to increase output torque significantly. The torques for using VS5, VS15, and VS25 are higher than those without VS. In general, Figure 7 also shows that the torques surges as engine speed increases and plummets after reaching a maximum value at a particular velocity. A similar torque trend was also observed by Efemwenkiele et al. [18] during their work on "An Investigation of Spark Ignition Engine Performance using Ethanol and Gasoline Blend". The maximum torque of 12.04 Nm was generated at 9750 rpm. The maximum torque using VS25 is due to the highest output power of the engine. Since the torque is proportional to the output power at a particular engine rotational speed as indicated in Eq. (2). The decreasing torque at higher engine rotational speed, i.e. greater than 9750 in this research, is due to increasing friction loss and decreasing volumetric efficiency at high velocity [19].

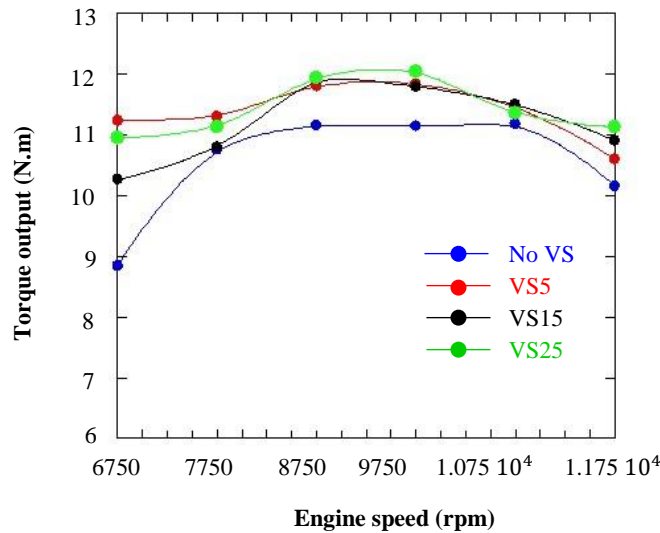

Figure 7 Torque

### 3.4 Specific fuel consumption

The effect of the velocity stack on specific fuel consumption is presented in Figure 8. The graph indicates that the use reduces fuel consumption considerably, hence, the engine is more efficient while using VS, i.e., more power is generated per unit mass of motor spirit. Specific fuel consumption depends mainly on output power and fuel consumption [20]. This indicates that better combustion occurs as a result of more air entering the ignition chamber by using a velocity stack, which is responsible for the leaner air-fuel mixture. Higher efficiency and power output are obtainable with leaner mixtures [16].

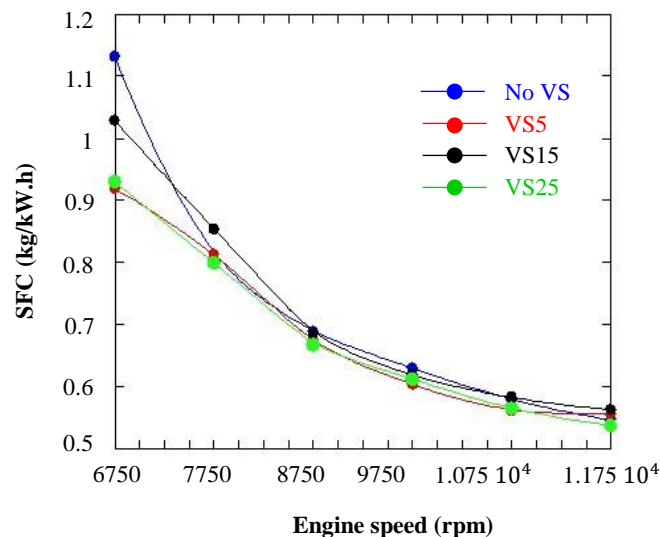

Figure 8 Specific fuel consumption

## 4. Conclusion

The effect of the three different geometry of velocity stacks on engine performance, torque, and specific fuel consumption has been explored. It is concluded that the engine performance increases while using a velocity stack of VS5, VS15, and VS25. Meanwhile, the torque and power output amplify slightly as the VS fillet radius increases. The airflow rate rises as the fillet radius of the velocity stack inlet increases, which enhances the combustion process, amplifies power output and torque, and reduces specific fuel consumption.

## 5. Acknowledgment

The authors sincerely appreciate The Department of Mechanical Engineering-Institut Sains dan Teknologi AKPIRND Yogyakarta for the facility support during this research.

## 6. References

- [1] Onawumi AS, Fayomi OSI, Okolie STA, Adio TA, Udoye NE, Samuel AU. Determination of a spark ignition engine's performance parameters using response surface methodology. *Energy Procedia*. 2019;157:1412-22.
- [2] Rocha DDD, de Castro Radicchi F, Lopes GS, Brunocilla MF, Gomes PCDF, Santos NDSA, et al. Study of the water injection control parameters on combustion performance of a spark-ignition engine. *Energy*. 2021;217:119346.
- [3] Cruccolini V, Discepoli G, Zembi J, Battistoni M, Mariani F, Grimaldi CN. Experimental assessment of a pressure wave charger for motorcycle engines. *Energy Procedia*. 2018;148:1254-61.
- [4] Deng B, Chen Y, Liu A, Xu Z, Hu S, Fu J, et al. The excess air coefficient effect on the performances for a motorcycle twin spark gasoline engine: a wide condition range study. *Appl Therm Eng*. 2019;150:1028-36.
- [5] Ceviz MA, Akin M. Design of a new SI engine intake manifold with variable length plenum. *Energy Convers Manag*. 2010;51(11):2239-44.
- [6] Silva EAA, Ochoa AAV, Henríquez JR. Analysis and runners length optimization of the intake manifold of a 4-cylinder spark ignition engine. *Energy Convers Manag*. 2019;188:310-20.
- [7] Reddy YS, Jabihulla Shariff Md, Ashok D, Babu KR. Experimental analysis of convergent inlet manifold for IC engines. *Mater Today Proc*. 2020;33:668-74.
- [8] Sharma V, Dhauni S, Chawla VK. Design and manufacturing of air intake assembly for formula SAE vehicle. *Mater Today Proc*. 2021;43:58-64.
- [9] Gocmen K, Soyhan HS. An intake manifold geometry for enhancement of pressure drop in a diesel engine. *Fuel*. 2020;261:116193.
- [10] de Souza GR, de Castro Pellegrini C, Ferreira SI, Pau FS, Armas O. Study of intake manifolds of an internal combustion engine: a new geometry based on experimental results and numerical simulations. *Therm Sci Eng Prog*. 2019;9:248-58.
- [11] Leroy T, Chauvin J, Petit N. Motion planning for experimental air path control of a variable-valve-timing spark ignition engine. *Control Eng Pract*. 2009;17(12):1432-9.
- [12] Teodosio L, Pirrello D, Berni F, de Bellis V, Lanzafame R, D'Adamo A. Impact of intake valve strategies on fuel consumption and knock tendency of a spark ignition engine. *Appl Energy*. 2018;216:91-104.
- [13] Morrone P, Algieri A, Bova S. Development of a lumped model for the characterisation of the intake phase in spark-ignition internal combustion engines. *Energy Procedia*. 2016;101:590-7.
- [14] Nguyen D, Choi Y, Park C, Kim Y, Lee J. Effect of supercharger system on power enhancement of hydrogen-fueled spark-ignition engine under low-load condition. *Int J Hydrog Energy*. 2021;46(9):6928-36.
- [15] Lee J, Park C, Kim Y, Choi Y, Bae J, Lim B. Effect of turbocharger on performance and thermal efficiency of hydrogen-fueled spark ignition engine. *Int J Hydrog Energy*. 2019;44(8):4350-60.
- [16] Thomas A. Flame development in spark-ignition engines. *Combust Flame*. 1983;50:305-22.
- [17] Bayraktar H. Theoretical investigation of flame propagation process in an SI engine running on gasoline-ethanol blends. *Renew Energy*. 2007;32(5):758-71.
- [18] Efemwenkikie UK, Oyedepo SO, Idiku UD, Uguru-Okorie DC, Kuhe A. Comparative analysis of a four stroke spark ignition engine performance using local ethanol and gasoline blends. *Procedia Manuf*. 2019;35:1079-86.
- [19] Verma A, Dugala NS, Singh S. Experimental investigations on the performance of SI engine with ethanol-premium gasoline blends. *Mater Today Proc*. 2022;48:1224-31.
- [20] Reddy KS, Aravindhan S, Mallick TK. Investigation of performance and emission characteristics of a biogas fuelled electric generator integrated with solar concentrated photovoltaic system. *Renew Energy*. 2016;92:233-43.